

PLAS-TIES

From Bagels To Cables...



XL-2 Manual

General Information

Thank you for your purchase of the XL-2 from Plas-Ties, manufacturers of high quality twist tying equipment.

Please familiarize yourself and/or any persons operating this machine with all functions by carefully reading this manual.

The XL-2 machine can be adjusted to tie almost any product gathered into a round shape from 3/8" diameter up to a maximum of 2" diameter.

High quality Plas-Ties tying ribbon is available in various spool lengths, colors and strengths. Your dealer or Plas-Ties Customer Service will assist with your replacement ribbon requirements.

Electrical power requirements for operating this XL-2 are found on the serial plate.

Operating Instructions

How The XL-2 Functions

Before operating or adjusting the XL-2, please read this section

The XL-2 machine will twist tie product(s) inserted into the tying area. The XL-2 machine can be adjusted to twist tie almost any product gathered into a round shape from 3/8" diameter up to a maximum of 2" diameter.

Stage 1: Product to be tied is manually inserted into the tying area and the product must come into contact with trigger switch. Trigger switch activates the XL-2 tying cycle and the stop guide ensures proper positioning. (Cycle time is approximately 3 seconds).

Please Note:

*There is a second stop guide located on the underside of the top cover.
The top guide should be aligned with the bottom guide.*

Stage 2: Trigger switch activates the capacitor in the main drive motor to rotate a single revolution that causes the main timing cam to rotate clockwise.

Stage 3: The main timing cam activates the cutter cam follower, which in turn activates the Ribbon cutter knife.

Stage 4: Simultaneously to Stage 3, the scissor actuator assembly pulls the scissors forward and around the product in the tying area. The ribbon-forming arm ensures that the pre-cut ribbon is centered to the tying area and then lifts out of the way.

Stage 5: With the rotation of the main timing cam being approximately one halfway through its cycle, the ribbon will be around the product and the ribbon ends are positioned in front of the twister.

Stage 6: As the main timing cam completes its cycle, the twister activates, twisting the ribbon ends and securing the ribbon around the product. As the ribbon is twisted, the scissors retract to their home position.

Stage 7: As the scissors return to their home position, switches are activated which in turn activate the ribbon feed drive wheel and it presses against the ribbon idler wheel. The ribbon is fed between these wheels and gets pulled through at this time. The ribbon continues through the ribbon chute where it will stop until Stage 1 commences again.

Operating Instructions

Threading and Changing Ribbon Spool

Step 1: Turn the power switch “OFF”, unplug the power cord and remove any ribbon pieces and/or debris inside the XL-2.

Step 2: Remove empty ribbon spool by depressing the brake spool arm and then pull the spool straight away from brake spindle. Slide the new ribbon spool onto brake spindle. Feed the ribbon from the top of spool to under and around the roller wheel on the brake assembly.

Step 3: With the ribbon now directed toward the rear of the XL-2, look at both sides of the ribbon. One side has a “bump” (wire), the other is flat. Pull 1 foot of ribbon from the spool and feed into the rear of the XL-2.

Step 4: Turn the pressure release cam to separate the ribbon drive wheel and insert the ribbon through the ribbon guide, ensuring that the “bump” (wire) side is against wheel and into the cutter anvil guide, but not protruding beyond the cutter space.

Step 5: Release the pressure release cam to bring the ribbon drive wheel together, making sure the ribbon is between the restraint flanges on the ribbon drive wheel.

Tying Operation

Step 1: Support the product to be tied with both hands and insert into the left side of tying area when tying in the vertical position. **Insert into bottom of tying area when in the horizontal tying position.*

Step 2: Hold the product in place until the product is twist tied. Tying cycle is approximately 3 seconds.

Step 3: The product may be removed from the tying area any time after the tying cycle is complete.

Please Note:

Periodically the ribbon length will need to be either lengthened or shortened. Slightly turn the Tying Diameter Adjustment Dial to the left to decrease ribbon length and to the right to increase ribbon length.

Always remove any ribbon pieces from the XL-2 before tying.

Adjusting Tying Diameter

Adjusting XL-2 Tying Diameter

Caution

Before attempting any adjustments of this machine, the power switch should be in the "OFF" position and the power cord disconnected.

The XL-2 machine can be adjusted to twist tie almost any product gathered into a round shape from 3/8" up to a maximum of 2" diameter. Prior to adjusting any internal components of the XL-2, you must pre-determine the following:

1. Material Diameter
2. Chute Length
3. Ribbon Length

Step 1: Set Tying Diameter Dial

1. Rotate tying diameter adjustment dial to point arrow to the desired product diameter. This diameter will then align with and indicate ribbon length and the required chute length. Example: if the tying diameter is 2", then the chute length is 4" and the ribbon length is 9.5".

Step 2: Adjust Stop Guides

1. Loosen screw and move the stop guide to the correct product diameter.
2. Tighten screw. This aligns and centers the product to be tied directly in front of the twist shaft. **Top guide is under top cover and should be adjusted to align with bottom guide.*

Step 3: Adjust Ribbon Drive Motor

1. Loosen the sockethead cap screw and slide the entire ribbon drive assembly to align with required ribbon length as indicated from Step 1.
2. Retighten the sockethead cap screw.

Step 4: Change Ribbon Chute

1. Remove screw and washer and swing scissor actuator rod out of the way.
2. Loosen screw and washer and lift out chute.
3. Install new ribbon chute and tighten screw. (Be certain that the ribbon chute is centered to the slot in the ribbon cutter anvil.)
4. Re-thread ribbon through machine.

Step 5: Test Tying Material

1. Reconnect power supply and turn the power switch on.
2. Insert desired material into left side of tying area and activate the tying cycle.
3. Fine tune ribbon length if required, by slightly rotating the Tying Diameter Adjustment Dial to achieve optimum ribbon length.

Problems and Solutions

Troubleshooting

The following information is given as an aid for readily identifying any malfunctions which may occur during the operation of the Tie-Matic XL-2.

	CONDITION	CAUSE	REMEDY
Missing Ties	Ribbon around product but not twisted	a. Incorrect ribbon length b. Twister installed backwards	a. Adjust for longer length ribbon (see pg. 8) b. Unscrew twister and reinstall 180°
	Above problem but not consistent	a. Possible malfunction of Time Delay Relay yielding sporadic ribbon length	b. Replace Time Delay Relay
	Ribbon is carried back with scissors	a. Safety device on arm is releasing. Scissors not arriving at full forward position b. Cutter knife has misaligned	a. Remove ribbon from scissors. Determine if safety device is working properly. b. Adjust cutter anvil guide (see pg. 18)
No Ribbon Feed	Ribbon drive motor operates, but no ribbon is driven out	a. Ribbon drive pressure wheel is not in contact with ribbon drive wheel. b. Chain sprocket loose on drive wheel	a. Refer to pg. 6 to check if ribbon is threaded correctly b. Check sprocket, tighten set screw
	Ribbon jams behind anvil	a. Interference with ribbon feed b. Misalignment of scissors c. Knife not returning to home position d. Return spring broken or not assembled e. LS-3 (Bottom switch) is releasing first as scissors leave home position	a. Clear ribbon path of debris b. Scissor adjustment (see pg. 18) c. Reset anvil position (see pg. 18) d. Check spring, replace if necessary e. Adjust LS_3 arm out so that both top (LS-2) & bottom (LS-3) switches activate in close unison
	Ribbon Motor does not run	a. LS-2 (Top switch) is out of adjustment b. Time Delay Relay is defective	a. Adjust LS-2 as in e) above b. Replace Time Delay Relay
Machine recycles constantly when holding in trigger switch		a. Control Relay is defective	a. Replace Control Relay
Machine will not cycle	Ribbon feeds out constantly	a. LS-3 (Bottom switch) is not activating on scissor return	a. Adjust LS-3 arm outward so that LS-2 and LS-3 activate in close unison
	Main drive motor M-1 runs	a. Trigger switch (LS-1) is out of adjustment	a. Adjust to hear a click upon releasing of trigger
	Depressing trigger has no effect	a. Trigger switch (LS-1) out of alignment b. Safety switch (LS-1) not closed c. Fuse blown	a. Adjust to hear a click upon closing trigger b. Adjust to hear a click upon closing cover c. Check fuse, replace if necessary
Tie is not tight		a. Ribbon length is too short	a. Increase the ribbon length (see pg. 8)

Major Component Description & Adjustments

Brake Assembly: Holds the ribbon spool and creates spool “drag”. No adjustment. See brake installation instructions.

Ribbon Chute: Guides the pre-cut ribbon through to the scissor. Critical that the chute is centered to the slot in the ribbon cutter anvil. Correct chute length must be utilized according to diameter of product. To adjust, see Scissor.

Ribbon Drive Motor: Pulls ribbon through machine. Adjustment is critical to ensure that desired length of ribbon is pulled through during the tying cycle. To adjust:

1. Loosen the sockethead cap screw.
2. Slide the entire ribbon drive assembly and align with the desired length mark on machine chassis.
3. Tighten the sockethead cap screw.

Stop Guide: Ensures product to be tied is centered to the twister. To adjust:

1. Loosen screw.
2. Align appropriate diameter to marker.
3. Tighten screw.

Tying Diameter Adjustment Dial: Provides visual calibration for product diameter, required ribbon chute length and ribbon length for the ribbon drive motor setting. It is also the fine-tuning adjustment controller for ribbon length.

Motor and Cam: Controls the timing functions of overall tying operation. Timing adjustment is critical. Correct setting has cam set in the home position when XL-2 is inactive. The home position is correct when bearing is positioned in notch. To confirm and adjust this setting:

1. Disable ribbon feed by turning idler lockout and then activate the tie cycle once.
2. Check cam position for home position.
3. If setting is not correct, loosen wing nut.
4. Turn screw. (Clockwise = delay) (cc = advance)
5. Test cycle to confirm. Tighten wing nut when correct.
6. Turn idler lockout to engage ribbon feed.

Scissor: Places the ribbon around the product to be twist tied. Alignment is critical. Correct setting has the ribbon chute centered to the ribbon cutter Anvil slot. To adjust:

1. Remove screw and washer.
2. Loosen one of the locknuts on the scissor-actuating rod.
3. Turn rod bearing until the ribbon chute on the scissor is centered to the slot in the Ribbon Cutter Anvil.
4. Tighten locknut and reinstall screw and washer.

Twister: Twists ribbon ends securing the ribbon around the product. Twister position is critical. Correct position is in a vertical position when inactive. To adjust:

1. Loosen twister sprocket set screw.
2. Turn twister and shaft until twister is in a vertical position.
3. Re-tighten setscrew.

Major Component Description & Adjustments

Ribbon Cutter: Cuts the ribbon to length. Smooth action between knife and cutter anvil is critical. To adjust:

1. Lift cutter cam follower and rotate cutter cam clockwise until the cutter cam follower rests on the lobe of the cutter cam.
2. Loosen the screws that secure the cutter anvil.
3. Hold the cutter anvil against the knife.
4. Retighten the screws.

Important Make certain that the knife is not too tight. The knife must not “stick”, but be secure enough to cut the ribbon cleanly.

Brake Assembly and XL-2 Mounts

Brake Assembly Installation

Vertical Mount - Tying product in a vertical Position

(Standard equipment – use with large or small brake)

1. Mount assembly on mounting place using two screws provided.
2. Follow ribbon installation and threading instructions (see operating instructions).

Horizontal Mount – Tying product in a horizontal position

(Optional part# 56108. Use with large brake only)

1. If currently set up for horizontal operation, remove brake assembly by removing the two screws.
2. Mount brake assembly on mounting plate with the same screws.
3. Lay machine on left side so that it is supported by the mounting stand.
4. Bolt the side mount stand to the XL-2 external chassis bracket.
5. Follow ribbon spool installation and threading instructions (see operating instructions).



Vertical Mount with Pedestal Stand



Horizontal Mount with Pedestal Stand

Pedestal Mount – Tying product in either position

(Optional part# 505R033, plus use special brake# 505D231-1)

1. Remove cover and micro switch/safety switch.
2. Loosen capacitor.
3. Pull apart Molex 9 pin connector.
4. Remove legs from bottom of chassis and remount to pedestal.
5. Reinstall / tighten / reconnect steps 1,2,3.

Please Note:

The Brake Beam positioning has the Roller Assembly pointed down when installed on the Pedestal Mount.

PLAS-TIES

XL-2 Parts Chart

as of 8/16/10

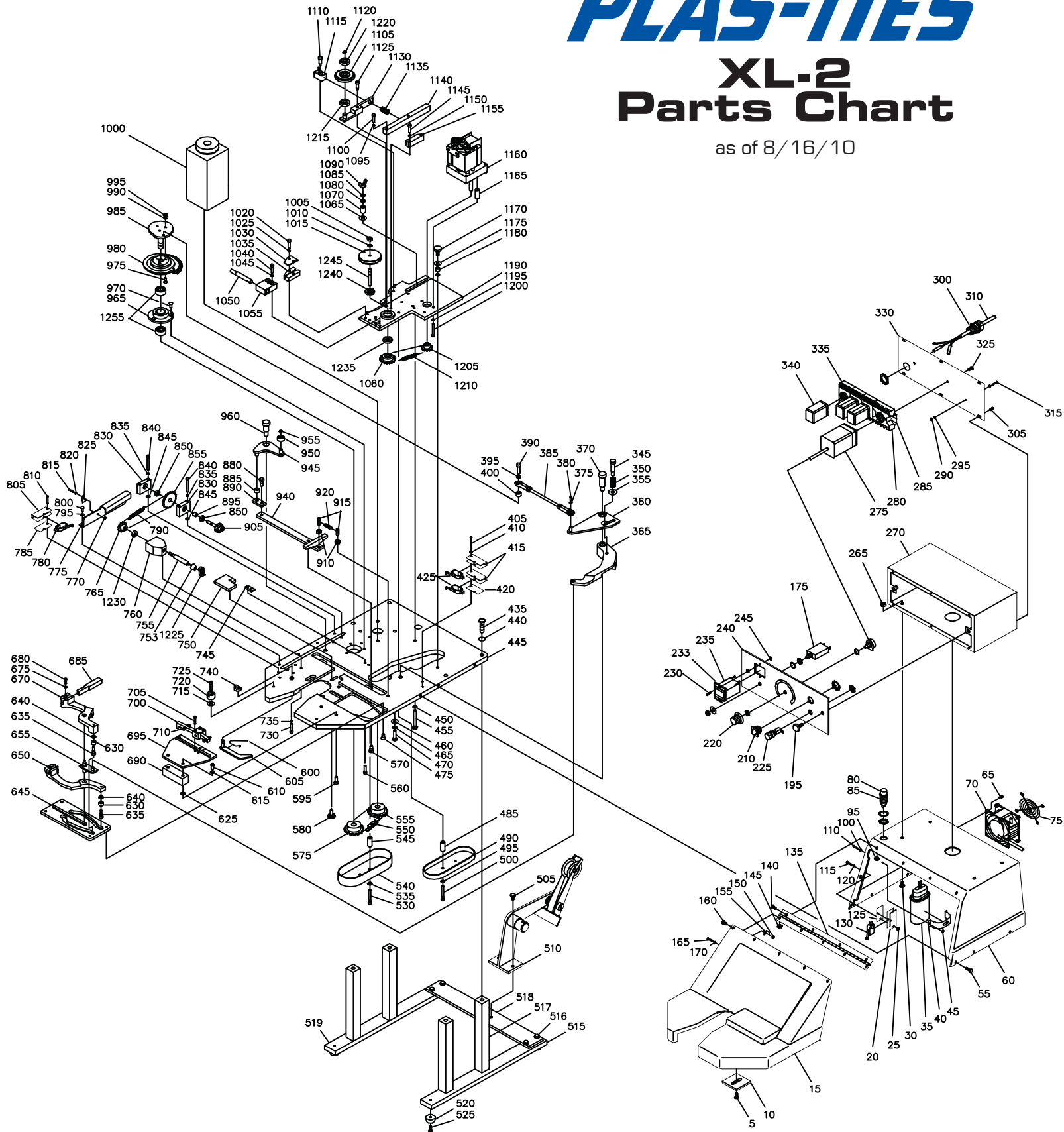

XL-2 PARTS LIST FOR POSTER			
as of 8/16/2010			
ITEM #	PART #	DESCRIPTION	QTY
5	56715	Screw - Button Head Cap 1/4-20 x .500	1
10	505B184	Stop - Upper	1
15	505R182	Hinged Cover	1
20	M001050	Insulator - Switch	1
25	56501	Nut - Hex 4-40	2
30	56704	Screw - Phillips Head 1/4-20 x .500	4
	P001450	Lockwasher - Internal Tooth No. .250	4
35	506358	Capacitor (7.5 mfd)	1
37	56913	Rubber Cover for Capacitor	1
40	16932	Clamp - Metal Capacitor	1
45	56501	Nut - Hex 4-40	2
55	56755	Screw - Pan Head Phillips 10-24 x .500	9
60	M022050	Fixed Cover - Rear	1
65	P001220	Screw - Pan Head Phillips 8-32 x .375	4
70	56823	Axial Fan	1
75	56824	Fan Guard	1
80	56903	Light Bulb	1
85	56902	Light Holder Assembly	1
95	56500	10-32 Kepnet Hex Nut	1
100	P001460	#4 Internal Tooth Lockwasher	2
110	P004364	4-40 x 7/8 Phillips Pan Head Screw	2
115	P004364	4-40 x 7/8 Phillips Pan Head Screw	2
120	P001460	#4 Internal Tooth Lockwasher	2
125	M001200	Switch Spacer	1
130	P001570	Micro Switch	1
135	505B183	Hinge	1
140	506336	10-32 x 3/8 Pan Head Slotted Screw	4
145	56500	10-32 Kepnet Hex Nut	4
150	P001070	Nut - Hex 8-32	1
155	M030000	L Bracket	1
160	506336	10-32 x 3/8 Pan Head Slotted Screw	5
165	P001270	Screw - Pan Head Phillips 8-32 x .500	1
170	P001470	#8 Internal Tooth Lockwasher	1
175	P001580	Circuit Breaker, 115v, 2 amp	1
195	14432	Black Thumb Screw	2
	56703	1/4 20 x 1 1/2 Socket Head Cap Screw	2
210	56925	Rocker Switch	1
220	56905	Control Knob	1
225	56908	Fuse Holder	1
230	18034	6/32 x 1/2 Flat Head Screw	2
233	M001040	Counter Seal	1
235	P001760	Counter	1
240	505C225	Front Cover	1
245	16961	6-32 Hex Nut	2
265	P001080	1/4-20 Hex Nut	4
270	505D142	Electrical Chassis	1
275	505B132	Time Delay Relay	1

ITEM #	PART #	DESCRIPTION	QTY
280	569340	Timer Socket	1
285	506347	Din Rail	1
290	56501	4-40 Hex Nut	1
295	P001460	#4 Lock Washer	1
300	56403	Strain Relief	1
305	56930	8-32 x 3/8 Phillips Sheet Metal Screw	6
310	A301010	Power Cord Assembly	1
315	56960	4-40 x 5/8 Screw	1
325	506336	10-32 x 3/8 Slotted Pan Head Screw	2
330	505C190	Back Cover	1
335	56933	Socket Relay	3
340	56922	Power Relay	3
345	56825	3/8-16 x 2 Shoulder Bolt	1
350	56929	Spring	1
355	505B210	Spring Detent	1
360	M021570	Arm Scissor Actuator	1
365	A202150	Arm Actuator Assembly	1
370	505B114	1/2-13 x 1 1/4 Shoulder Bolt 1/2 Dia.	1
375	56801	# 4 Flat Washer	3
380	56785	5-40 x 3/8 Socket Head Cap screw	1
385	A202120	Rod Scissor Actuator Arm Assembly	1
390	P004150	1/4-28 x 1 Socket Head Cap Screw	1
395	56805	1/4 Split Lock Washer	1
400	505B129	Space - Cutter Cam	1
405	P004858	4-40 x 1 1/4 Phillips Head Screw	2
410	P001460	# 4 Lock Washer	2
415	M001050	Switch Insulator	2
420	M001200	Switch Spacer	1
425	P001570	Micro Switch	2
435	P004706	3/8-16 x 1 Socket Head Cap Screw	4
440	P004715	3/8 Split Washer	4
445	505D173	Frame	1
450	56805	Lockwasher - Internal Tooth No. .250	1
455	1160	1/4-20 x 2 Hex Head Screw	1
460	56802	# 10 Flat washer	4
465	506337	# 10 Split Lock Washer	4
470	P003420	10-32 x 1 Socket Head Cap Screw	4
475	56738	Screw - Flat Head Socket Cap 10-24 x .500	4
485	M030012	Spacer	2
490	505B155	Guard Ribbon Drive	1
495	56802	# 10 Flat washer	2
500	P001431	10-24 x 1/2 Flat Hex Socket Screw	2
505	56704	1/4-20 x 1/2 Phillips Pan Head	2
510	A102022	Small Brake Assembly	1
	A102021	Large Brake Assembly	1
	A102020	Special Brake	1
515	505C166	Right Foot	1
516	56708	1/4-20 x 3/4 Socket Head Cap Screw	4
517	505B163	Leg Frame	4

ITEM #	PART #	DESCRIPTION	QTY
518	505C164	Back Mounting Plate	1
519	505C165	Left Foot	1
520	P001540	Rubber Foot	4
525	56710	10-24 x 5/8 Screw	4
530	P001431	10-24 x 1/2 Flat Hex Socket Screw	2
535	56802	# 10 Flat washer	2
540	M021402	Chain Cover	1
545	M026419	Spacer	2
550	A401650	# 35 Chain 13 1/2" Long	1
555	M021601	Sprocket	1
560	P003540	Screw - Shoulder Bolt 10-24 x .250Dia x .375 L	1
570	505B112	5/16 x 1/4 Shoulder Bolt	1
575	M021411	Sprocket	1
580	56715	1/4-20 x 1/2 Hex Button Head Screw	1
595	56724	1/4-20 x 3/4 Hex Flat Head Screw	2
600	505B177	Trigger Spring	1
605	505B013	Trigger Arm	1
610	56715	1/4-20 x 1/2 Hex Button Head Screw	2
615	P001450	1/4 Lockwasher - Internal Tooth	2
625	M022065	.005 Stainless Shim	2
630	56001	Bearing	2
635	56723	1/4-20 5/16 Shoulder Bolt	2
640	505B202	Spacer	2
645	505C105	Cam Scissor Guide	1
650	A202180	Scissor Arm Left Assembly	1
655	505B010	Drag Link	1
670	A202170	Scissor Arm Right Assembly	1
675	P001470	#8 Lock Washer- Internal Tooth	2
680	P001220	8-32 x 3/8 Phillips Head Screw	2
685	CHUTES		
	505B215	1 1/2 " Chute Optional	1
	505B216	2 " Chute Optional	1
	505B217	2 1/2 " Chute Optional	1
	505C218	3 " Chute Optional	1
	505C219	3 1/2 " Chute Optional	1
	505C220	4 " Chute Optional	1
690	M021040	Support Block	1
695	505C103	Scissor Arm Cover	1
700	A202110	Ribbon Lever Assembly	1
705	56712	6-32 x 3/4 Socket Head Cap Screw	4
710	56602	O'Ring	8
715	505M001	Spacer	2
720	56906	Magnet	2
725	506338	10-24 x 7/8 Socket Head Cap Screw	2
730	506337	# 10 Split Washer	4
735	56719	10-24 x 3/4 Hex Socket Head Cap Screw	4
740	505B176	Cam Actuator Bracket	1
745	505B144	Slide Return Plate	1

ITEM #	PART #	DESCRIPTION	QTY
750	505B180	Lower Stop Plate	1
753	M001880	Cone	1
755	M021365	Twister Shaft	1
760	A202090	Twister Support Assembly	1
765	505B117	Sprocket	1
770	56501	4-40 Hex Nut	2
775	505B122	Twister Chain Guard	1
780	P001570	Micro Switch	1
785	M001200	Insulation Spacer-Switch	1
790	A401640	#25 Chain 16 1/2 Long	1
795	56802	# 10 Flat Washer	3
800	P001430	Screw - Socket Head Cap 10-24 x 1/2	3
805	M001050	Insulation-Switch	1
810	P004362	4-40x1 Phillips Pan Head	2
815	56960	4-40x5/8 Screw	2
820	56801	# 4 Flat Washer	2
825	56900	Nylon Cable Clamp	2
830	505B019	Support- Twister Drive	2
835	506337	# 10 Split Lock Washer	4
840	56705	10-24 x 1 1/2 Screw	4
845	56914	.005 Shim	4
850	P001020	Bearing -	2
855	A001741	Twister Sprocket	1
880	56726	1/4-20 Shoulder Bolt 5/16 Dia.	1
885	505B129	Spacer - Cutter	1
890	505B130	Link Cutter Actuator	1
905	M001492	Pinion Shaft Assembly	1
910	P001080	1/4-20 Hex Nut	1
915	56711	1/4-20 x 1 Cup Point Set Screw	1
920	M001484	Spring Tension	1
940	505B133	Connector - Cutter Link	1
945	A202130	Bell Crank Assembly	1
950	56002	Bearing	1
955	P001180	Snap Ring	1
960	56100	3/8-16 x 3/4 Shoulder Bolt 1/2 Dia.	1
965	A202040	Support - Cutter Cam Assembly	1
970	56729	10-24 x 1/2 Flat Hex Socket Screw	3
975	56729	10-24 x 1/2 Flat Hex Socket Screw	3
980	505C127	Gear Segment	1
985	505B012M	Cam Actuator	1
990	506337	# 10 Split Washer	3
995	56506	10-24 Hex Nut	3
1000	56959	Bodine Motor	1
1005	56503	1/4-28 Hex Nut	1
1010	56805	1/4 Split Washer	1
1015	A302050	Ribbon Feed Wheel Assembly	1
1020	56719	10-24 x 3/4 Hex Socket Head Screw	2
1025	506337	# 10 Split Washer	2
1030	505B168	Cover	1

ITEM #	PART #	DESCRIPTION	QTY
1035	505B169	Knife Anvil	1
1040	56719	10-24 x 3/4 Hex Socket Head Screw	2
1045	506337	# 10 Split Washer	2
1050	505B153	Ribbon Cutoff Knife	1
1055	A302030	Cutter Support Block Assembly	1
1060	505B158	Sprocket	1
1065	56803	1/4 Dia. Washer	1
1070	506352	Nylon Spacer	1
1080	56810	1/4 Flat Washer	1
1090	1113	Wingnut	1
1095	506337	# 10 Split Lock Washer	2
1100	506338	10-24 x 7/8 Socket Head Cap Screw	2
1105	A302060	Pressure Wheel Assembly	1
1110	505B113	10-24 x 1/4 Dia. X 5/8 lg. Shoulder Bolt	1
1115	505B170	Cam Pressure Block	1
1120	56606	Retaining Ring	1
1125	505B113	10-24 x 1/4 Dia. X 5/8 lg. Shoulder Bolt	1
1130	505B150	Support Idler	1
1135	56940	Spring Tension	1
1140	505B152	Ribbon Guide Flat Long	1
1145	506338	10-24 x 7/8 Socket Head Cap Screw	2
1150	506337	# 10 Split Lock Washer	2
1155	505B151	Ribbon Guide Flat Short	1
1160	505C027-1	Motor 110 Volt	1
1165	M030010	Stain Off	4
1170	14432	Black Thumb Screw	1
1175	56803	1/4 Dia. Washer	1
1180	505B119	Spacer Ribbon	1
1190	505D157	Ribbon Drive Slide Plate	1
1195	P001470	# 8 Internal Tooth Lock Washer	4
1200	P001270	8-32 x1/2 Phillips Head Screw	4
1205	505B159	Sprocket Ribbon Drive	1
1210	A401645	# 25 Chain 12 1/2" Long	1
1220	56006	Bearing	1
1225	505B212-4	Twister	1
1230	P001020	Bearing	1
1235	56005	Bearing	1
1250	P001030	Bearing	2

ASSEMBLIES

ASSEMBLIES			
	A202040	Support Cam Cutter Assembly	
	505B126	Support Cam Cutter	1
	P001030	Bearing	2
	A202120	Rod Scissor Actuator Assembly	
	505B230	Rod Scissor Actuator	1
	56000	Rod End Bearing (Right)	1
	56009	Rod End Bearing (Left)	1
	56805	Split Washer 1/4	2
	56503	Hex Nut 1/4-28 RH Thread	1
	P001095	Hex Nut 1/4-28 LH Thread	1
	505B019	Support Twister Drive Assembly	
	505B121	Support Twister Drive	1
	P001020	Bearing	1
	A001741	Sprocket, Twister Drive	
	M001741	Modified Sprocket	1
	M001742	Sprocket Clamp	1
	P002400	10-32 x 5/8 Socket Head Cap Screw	2
	A202090	Twister Support Assembly	
	505B120	Support Block	1
	P001020	Bearing	1
	56205	Bushing	1
	A202180	Scissor Arm Assembly (Left)	
	505C101	Scissor Arm (Left)	1
	56202	Bushing	1
	505B202	Washer Spacer	1
	56001	Bearing	1
	56723	Shoulder Bolt	1
	A202170	Scissor Arm Assembly (Right)	
	505C102	Scissor Arm (Right)	1
	56202	Bushing	1
	505B202	Washer Spacer	1
	56001	Bearing	1
	56723	Shoulder Bolt	1
	A202110	Ribbon Forming Lever Arm Assembly	
	505B221	Lever Forming Lever	1
	505B107	Support	1
	56912	Roll Pin	2
	56939	Dowel Pin	1
	56602	O'ring	8

A202150 Arm Actuator Assembly			
	505C209	Actuator Scissor Arm	1
	56200	Bushing	1
	56201	Bushing	1
A202060 Scissor Arm Actuator Assembly			
	M021570	Scissor Arm Assembly	1
	M021540	Pin	1
A302070 Plate, Ribbon Feed Assembly			
	505D157	Plate, Mounting Ribbon Guide	1
	505B201	Receiver Ribbon Drive Wheel	1
	56005	Bearing	2
A302060 Ribbon Idler Wheel Assembly			
	505B198	Wheel Pressure Ribbon Drive	1
	56006	Bearing	1
A302020 Lever Assembly Ribbon Wheel			
	505B149	Shaft, Ribbon Idler	1
	505B150	Support Idler	1
A302080 Idler Lock Out Cam Assembly			
	505B170	Cam, Pressure Wheel	1
	56910	1/8 x 1 Roll Pin	2
A301010 Power Cord Assembly			
	P001610	Power Cord, Black	1
	P001410	Connector, Quick Disconnect	1
	P001420	Terminal Ring Tongue	1
	P001670	Terminal , Male	1
	P001690	Connector Receptacle	1
	M001497	Strain Relief Connector	1
A401675 Electrical Harness Assembly			
	506340	Timer Socket	1
	56933	Socket Relay	3
	56931	Metal Jumpers	4
	505B132	Time Delay Relay	1
	56952	Fork Terminal, Pink	22
	P003980	Fork Terminal, Blue	4
	56922	Relay, Power	3
	56822	Relay Clips	3
	P001890	Connector, Plug	3
	P001690	Connector, Receptacle Male	3
	P003920	Receptacle, With Ears	1
	506347	Din Rail	1

PLAS-TIES XL-2 Electrical System Schematic & Functions

INDEX #	PART #	DESCRIPTION	QTY
1	506341	Capacitor	1
	56913	Capacitor Cover *	1
	16932	Capacitor Clamp *	1
2	505B222	Track, Mounting*	1
3	56933	Socket, Relay #RS-8	3
4	56922	Relay (115V) GV-DPDT-115A (K1, K2, K3)	3
	56822	Relay Clips *	1
5	506340	Socket, Timer	1
6	505B132	Relay, Time Delay (115V)	1
	56403	Strain Relief *	1
6A	Part of 6	Potentiometer for Time Delay Relay (R1)	1
	56905	Knob #409-D2-K1 *	1
7	56908	Fuse holder #342028 *	1
	56909	Fuse (115V) AGC-5 * (F1)	1
	16912	A.C. Cord *	1
9	56924	On/Off Switch and Lamp (S1 and L1) *	1
	56970	Optional Food Activated Switch *	1
10	505D142	Control Box Chassis	1
	505C190	Cover, Back *	1
	505C225	Cover, Front *	1
11	16953	Circuit Breaker 1.5 Amp * (CB1)	1
12	16907	Microswitch (LS1, LS2, LS3, LS4)	1
13	56926	Main Motor (M1)	1
	505B172	Main Motor Sprocket	1
	56928	Transformer #GSD-350(230V) Options	2
14	505C027-1	Ribbon Feed Motor (m2)	1
	505B158	Sprocket Ribbon Feed Wheel	1
	505B228	Sprocket	1

* Denotes not shown. LS4 is located on left side of enclosure, in front& under enclosure lid.

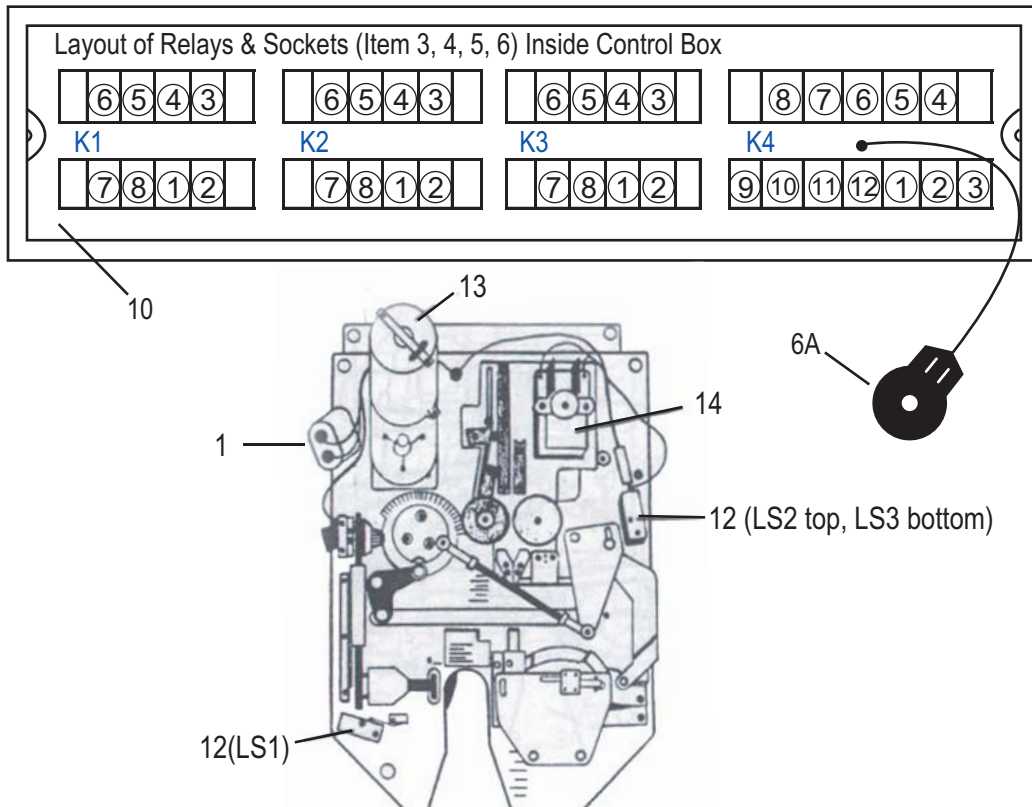

PLAS-TIES XL-2 Electrical System Schematic & Functions

Schematic illustrates condition of all switches when the XL2 is at rest (in between tying cycles) with cover closed (LS4) closed).

When the product to be tied is inserted into the tying area, Trigger Switch (LS1) closes and activates the main motor and cam. As the main motor and cam begin to turn, the cam closes top and bottom cam switches (LS2 & LS3) activating relay (K2 & K4).

Then, when the main motor and cam finish one complete rotation, the cam switches are re-opened causing three effects:

1. Relays (K1 & K3) are activated, disabling the main motor and cam.
2. Timing relay (k4) begin its delay cycle.
3. The ribbon feed motor begins to turn.

When timing relay (K4) times out (depending on the setting of the "Tying Adjustment Dial"), all relays deactivate, the ribbon feed motor shuts off, and the unit is once again at rest.

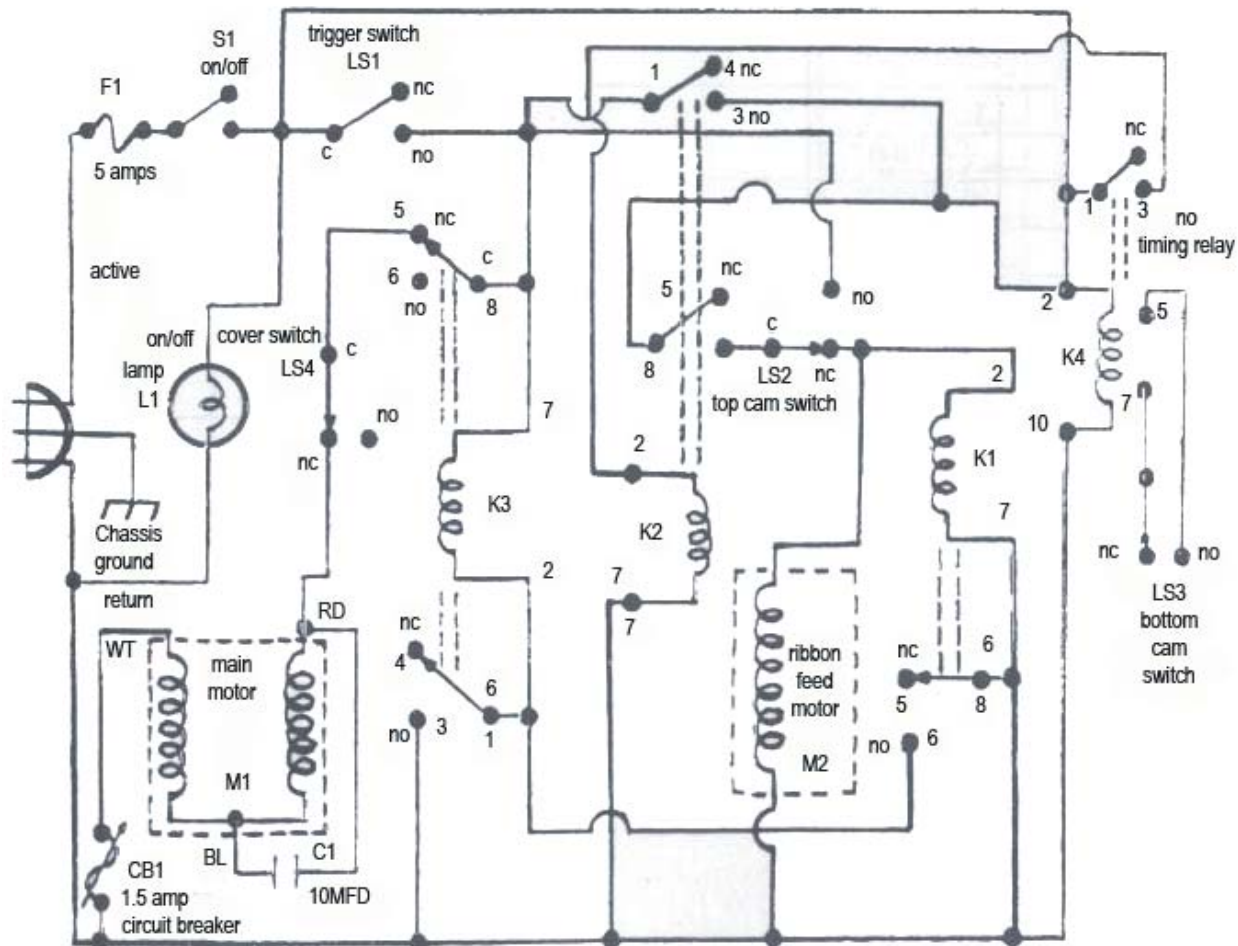

Maintenance

Never Over Lubricate

Lubricate with grease on the gears and chains, and with a light machine oil on moving parts.

* **Weekly**

℞ **Monthly**

* **Yearly**

	Schedule	Weekly	Monthly	Yearly
Machine				
Sprocket	℞			
Cam (Timing & Cutter)	℞			
Scissors	*			
Cutter (Adj.)	*			
Pressure Wheel	*			
Drive Wheel	*			
Switch (Trigger)	℞			
Chains	℞			
Sprockets	℞			
Brake Arm	*			
Gears	℞			
Thorough Component Check	*			
Electrical				
Motor	℞			
Switches	℞			
Lubrication				
Gears – Grease (LT)	℞			
Chains – Grease (LT)	℞			
Moving Parts & Pivots Oil (LT)	℞			
Safety				
Machine Cover	*			
Housekeeping				
Clean machine & area	*			

Warranty – Service – Ribbon Spools

XL-2 Replacement Ribbon Spools

High quality Plas-Ties tying ribbon is available in various spool lengths, colors, materials and strengths. Your dealer or Plas-Ties customer service will assist with your replacement ribbon spool requirement.

Please note that all spool lengths will fit machines equipped with the large brake or special brake assemblies and machines equipped with the small brake assembly can accommodate spools up to 2000'.

All spools are shipped in case lot with 5 spools per case. Colors include red, white, blue, green, yellow, orange, black, brown, and tan. Custom spools are available.

8.5" x 2" Wide Spools

Part# 311	2000' Plastic 27 ga 5/32" widths – all colors
Part# 312	2000' Plastic/Paper 27 ga 5/32" widths – all colors
Part# 313	1500' Plastic/Paper 24 ga 5/32" widths – all colors
Part# 314	1500' Plastic 24 ga 5/32" widths – all colors
Part# 316	2000' Paper 27 ga 5/32" widths – all colors
Part# 318	2000' Metallic 27 ga 5/32" widths – Red, Gold, Blue, Silver, Green

10" x 4" Wide Spools

Part# 303	4000' Plastic/Paper 24 ga 5/32" widths – White
Part# 101	3000' Paper 2-27 ga _" widths 1/8" spacing – White
Part# 102	2000' Paper 2-24 ga _" widths 1/8" spacing – White

Warranty – Service – Parts Information

From date of purchase, all components and workmanship of Plas-Ties equipment are warranted against normal usage defects for a period of 90 days. This warranty period commences on the date of purchase and excludes damage due to negligence, failure to use the equipment as instructed in this manual, operating the machine with ribbon material other than that of any unauthorized repair or modifications.

Warranty coverage is limited to the Continental United States, Alaska, Hawaii, Puerto Rico, and Canada.

For warranty, service, parts and replacement tying ribbon, call Plas-Ties customer service at 800-854-0137 Monday through Friday or by contact the dealer where originally purchased.